



Mil-Std-1553 Products

NHI-1530 Series

+5V Hybrid Dual Transceivers

Features:

- Compliant to Mil-Std-1553A & B
- Single +5V +/- 10% Supply
- Very Low Standby Power
- Short Circuit Proof
- Superior Noise Performance

Description:

The NHI-1530 series of Mil-Std-1553 hybrid dual transceivers are available in 1.900" x .780", 36 pin plug-in and flatpack packages. It operates off of a single +5V power supply with very low standby power dissipation.

Each receiver converts the 1553 bus bi-phase data to complementary RX and RX_L TTL digital outputs for use by the manchester decoder. The device provides independent receiver enables for each channel.

The transmitters will output bi-phase manchester to the coupling transformer when the TX and TX_L inputs are driven by complementary TTL digital data. The device provides an independent transmitter inhibit TXINH for each channel.

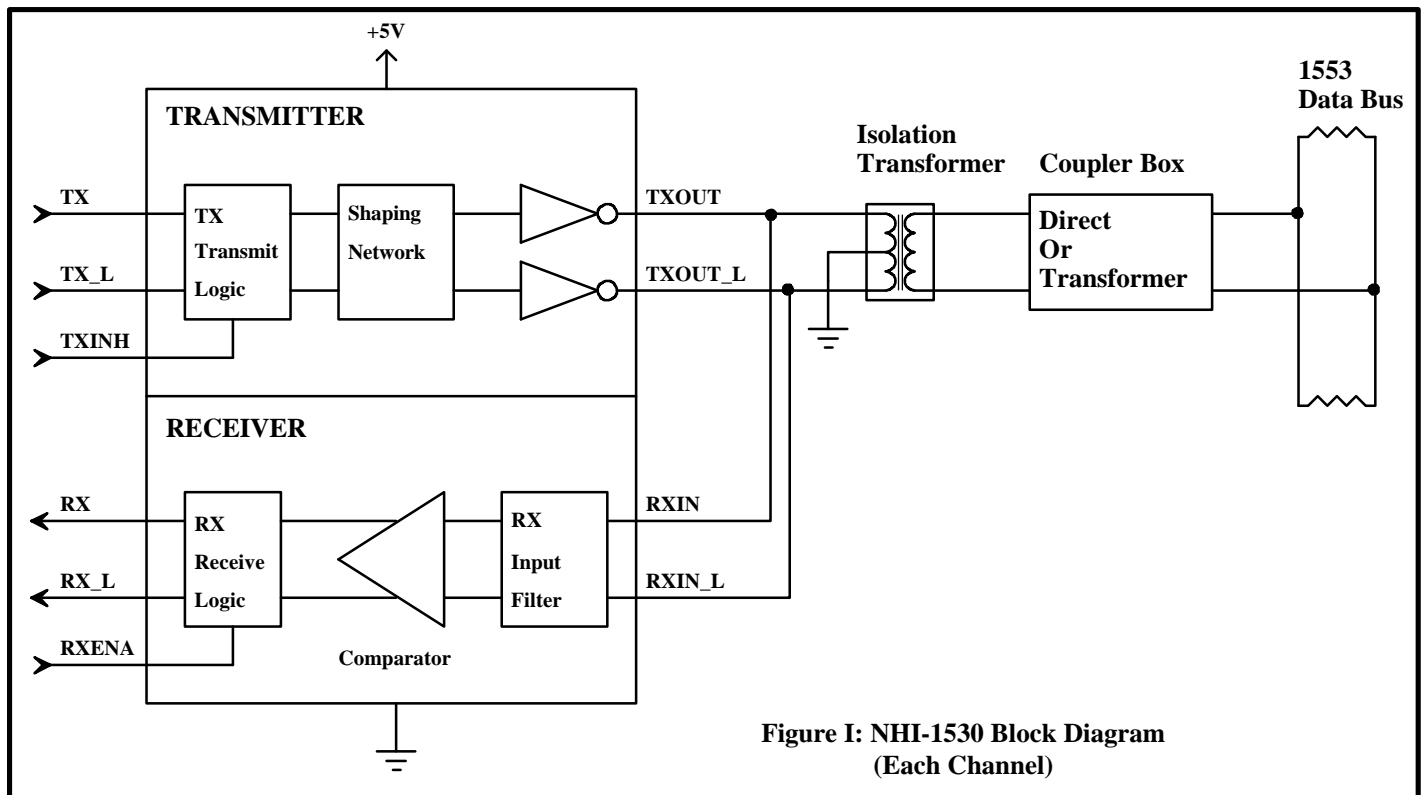

Figure I: NHI-1530 Block Diagram (Each Channel)

NHI-1530 Series

TABLE I: Electrical Specifications

Parameter	Condition	Symbol	Min	Typ	Max	Units
POWER SUPPLY REQUIREMENT		Vcc	4.7		5.5	V
TOTAL SUPPLY CURRENT	Vcc=5.0V, Not Transmitting	Icc1		30	40	mA
	Vcc=5.0V, Transmit one channel @ 50% duty cycle	Icc2		285	330	mA
	Vcc=5.0V, Transmit one channel @ 100% duty cycle	Icc3		535	600	mA
POWER DISSIPATION	Vcc=5.0V, Not Transmitting	Pd1			0.5	W
	Vcc=5.0V, Transmit one channel @ 100% duty cycle	Pd2			0.95	W
OPERATING TEMPERATURE	Junction	Tj	-55		175	°C
	Case	Tc	-55		125	°C
	Storage	Ts	-55		165	°C
THERMAL IMPEDANCE	Junction to Case (Hottest Die)	θjc			38.6	°C/W
LOGIC I/O						
RXENA_A, TXA, TXA_L, TXINH_A, RXENA_B, TXB, TXB_L, TXINH_B	Vcc= 5.5V, Vil= 0.0V	Iil			-0.8	mA
	Vcc= 4.5V, Vih= 2.7V	Iih			40	uA
RXA, RXA_L, RXB, RXB_L	Vcc= 5.5V, Iol= -4mA	Vol			0.4	V
	Vcc= 4.5V, Ioh= 400 uA	Voh	2.4			V
RECEIVER						
Input Resistance	Differential	Rin	10			k Ω
Input Capacitance	Differential	Cin			5	pF
Common Mode Rejection Ratio		CMRR	40			dB
Input Level	Differential	Vin			40	Vpp
TRANSMITTER						
Output Voltage	Across 35 Ω load	V _{out}	6	7.5	9	Vpp
Rise/Fall Time	10% to 90% of peak to peak output	t _r , t _f	100	150	300	nS
Output Dynamic Offset Voltage	Across 35 Ω load	V _{dyn}	-90		90	mV
Output Noise	Differential	V _{npp}			10	mVpp
Output Resistance	Differential, not transmitting	R _{out}	10			kΩ

NHI-1530 Series

Table II: Pin Functions

Pin#	Function	Pin#	Function
1	TXOUT_A	36	TXA_L
2	TXOUT_A_L	35	TXA
3	GND_A	34	TXINH_A
4	NC	33	+5V_A
5	RXA	32	NC
6	RXENA_A	31	GND_A
7	GND_A	30	RXIN_A_L
8	RXA_L	29	RXIN_A
9	NC	28	NC
10	TXOUT_B	27	TXB_L
11	TXOUT_B_L	26	TXB
12	GND_B	25	TXINH_B
13	NC	24	+5V_B
14	RXB	23	NC
15	RXENA_B	22	GND_B
16	GND_B	21	RXIN_B_L
17	RXB_L	20	RXIN_B
18	NC	19	NC

Transformer Requirements:

The NHI-1530 series requires a transformer with a turns ratio of 1:2.12 for Direct Coupling, and a turns ratio of 1:1.5 for Transformer Coupling to the Mil-Std-1553 Bus. Please contact Beta Transformer (www.bttc-beta.com) for a recommended transformer. The center tap on the transceiver side of the isolation transformer must be be grounded.

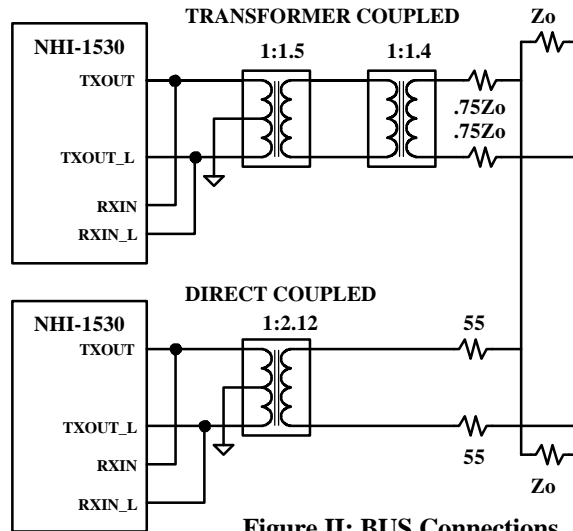

Figure II: BUS Connections

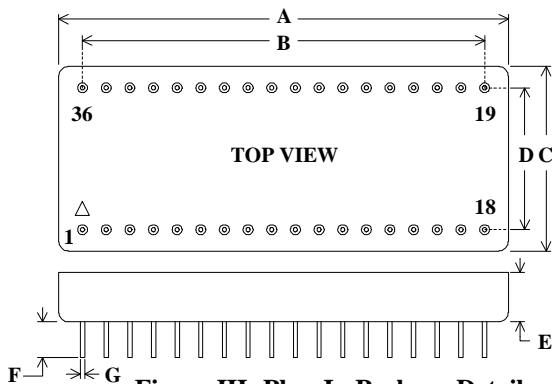

Figure III: Plug-In Package Detail

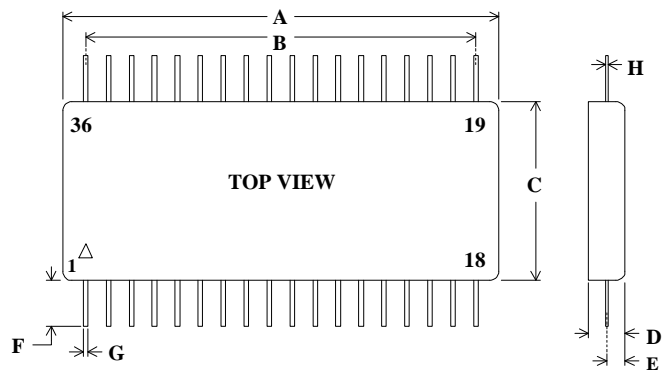

Figure IV: Flatpack Package Detail

Table III: Plug-In Dimensions

DIM	TYP (inches)	TOL (+/- inches)
A	1.900 "	0.010 "
B	17 EQ SP @	0.100 = 1.700 "
C	0.780 "	0.010 "
D	0.600 "	0.010 "
E	0.185 "	0.010 "
F	0.250 "	MIN
G	0.018 " DIA.	0.002 "

Table IV: Flatpack Dimensions

DIM	TYP (inches)	TOL (+/- inches)
A	1.900 "	0.010 "
B	17 EQ SP @	0.100 = 1.700 "
C	0.780 "	0.010 "
D	0.185 "	0.012 "
E	0.080 "	0.010 "
F	0.500 "	MIN
G	0.018 "	0.002 "
H	0.010 "	0.002 "

NHI-1530 Series

Transmit Waveforms

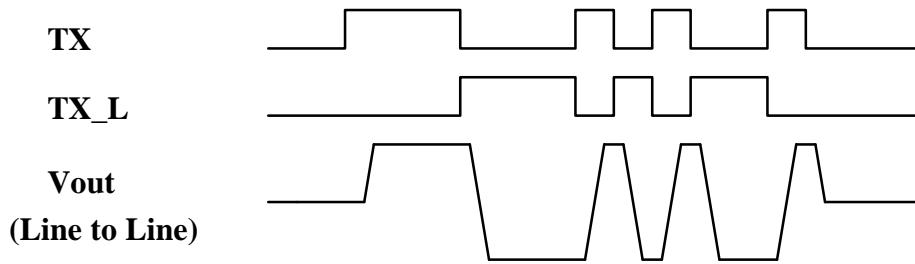

Transmitter Operation:

A high level input on TXINH will inhibit the transmitter outputs. If the TX & TX_L transmitter inputs are both high or both low, the transmitter is also inhibited. The output drivers are short circuit protected and the device will "fold back" to decrease power dissipation under this condition until the fault is removed.

Receive Waveforms

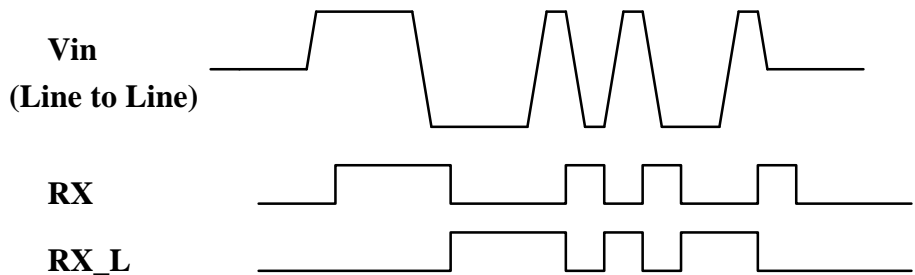

Receiver Operation:

A low level input on RXENA will disable the receiver outputs RX & RX_L regardless of bus activity. The receiver output compatibility may be specified as logic 0 or logic 1 when in standby mode.

** See Ordering Information

Ordering Information:

NHI-1530 FP / 883

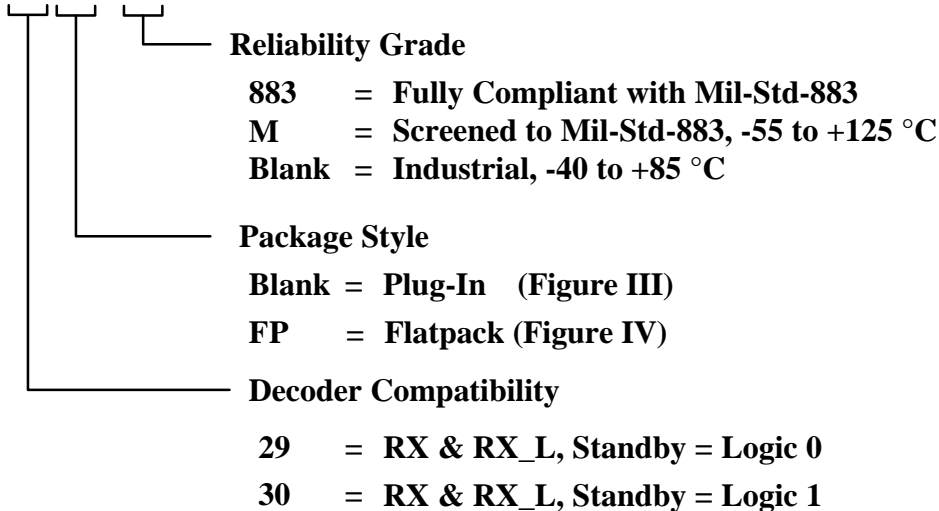

** SMD Listing: DESC Drawing# 5962-89522

See QML-38534 for NHI's Manufacturer Qualification Under Mil-PRF-38534



DATA DEVICE CORPORATION
 REGISTERED TO:
 ISO 9001:2008, AS9100C:2009-01
 EN9100:2009, JIS Q9100:2009
 FILE NO. 10001296 ASH09



The first choice for more than 50 years—DDC

DDC is the world leader in the design and manufacture of high reliability data interface products, motion control, and solid-state power controllers for aerospace, defense, and industrial automation.

Inside the U.S. - Call Toll-Free 1-800-DDC-5757

Headquarters and Main Plant

105 Wilbur Place, Bohemia, NY 11716-2426
 Tel: (631) 567-5600 Fax: (631) 567-7358
 Toll-Free, Customer Service: 1-800-DDC-5757

Web site: www.ddc-web.com



Data Device Corporation

Outside the U.S. - Call 1-631-567-5700

United Kingdom: DDC U.K., LTD

Mill Reef House, 9-14 Cheap Street, Newbury,
 Berkshire RG14 5DD, England
 Tel: +44 1635 811140 Fax: +44 1635 32264

France: DDC Electronique

10 Rue Carle-Herbert
 92400 Courbevoie France
 Tel: +33-1-41-16-3424 Fax: +33-1-41-16-3425

Germany: DDC Elektronik GmbH

Triebstrasse 3, D-80993 München, Germany
 Tel: +49 (0) 89-15 00 12-11
 Fax: +49 (0) 89-15 00 12-22

Japan: DDC Electronics K.K.

Dai-ichi Magami Bldg, 8F, 1-5, Koraku 1-chome,
 Bunkyo-ku, Tokyo 112-0004, Japan
 Tel: 81-3-3814-7688 Fax: 81-3-3814-7689
 Web site: www.ddcjapan.co.jp

Asia: Data Device Corporation - RO Registered in Singapore

Blk-327 Hougang Ave 5 #05-164
 Singapore 530327
 Tel: +65 6489 4801